

2014

WAIST HIGH TURNSTILE 3-ARM



TURNSTILE SECURITY SYSTEMS Inc.

THIS CATALOGUE IS MEANT AS
REFERENCE MATERIAL FOR TURNSTILE
SECURITY SYSTEMS Inc. FOR THE SOLE
PURPOSE OF INFORMING POTENTIAL
CUSTOMER OF FEATURE, ADVANTAGES
AND BENEFITS OF TURNSTILE SECURITY
SYSTEMS PRODUCTS.

7/11/2014

TURNSTILES- 3-ARM

Turnstile Security Systems Inc.'s 1100 series line of Waist High Turnstile provide an excellent means of controlling and counting the flow of pedestrian traffic in and out of your facility. Heavy duty construction, the latest in materials and manufacturing techniques ensure years of trouble free operation.

STANDARD EQUIPMENT:

- All bearings are permanently lubricated.
- Mechanically fitted arms (stronger than welded)
- 17" stainless steel arms.
- Stainless steel lid
- All locking and ratcheting components are hardened steel.
- Delrin main indexing cam for years of maintenance free reliability.
- Bronze oil-impregnated bushings.
- Adjustable hydraulic speed control.
- Black powder coated cabinet.

STANDARD ELECTRIC COMPONENTS:

- 24 Volt operating system.
- Adjustable time out delay.
- Fail safe or fail secure.
- Stainless steel lid
- Dry contact relay
- 12 Volt or 24 Volt pulse relay.
- Heavy duty pulls type solenoid.

OPTIONS:

- Card Readers.
- Token Boxes.
- Digital Counter.
- Powder Coat Finish
- 1 Or 2 Way Controlled.
- Indicating Lights
- Audible Signal
- Full Stainless Cabinet.

APPLICATIONS:

1100 series Turnstiles are designed to provide access control at locations such as commercial and industrial facilities, airports, schools amusement parks etc. turnstiles can be used wherever controlled access is required.

TURNSTILES

A Turnstile System consists of the turnstile itself and a rail. There is a positive complimentary relationship between the guide railing and the turnstile that determines the effectiveness of the turnstile control. Unless the guide railing is of a proper length, proper height and proper location in relation to the turnstile, the efficiency of the turnstile control can be, and usually is seriously impaired. The following illustrations show some of these common errors in installing turnstiles and guide railings, and they should be corrected.

In this installation, a person can slip through in the wrong Direction, between post and turnstile arm, By pulling the arm towards themselves.

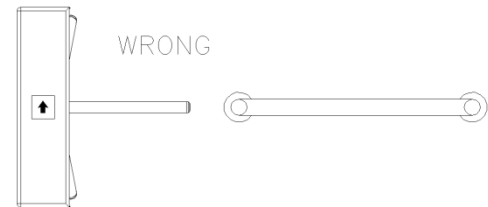

Install a correct guide railing parallel to the Turnstile Housing and at least 24" long. If the railing is not at least 24" a person may slip through in the wrong direction without engaging the arms.

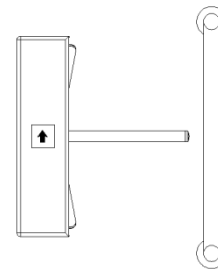

Wide gap between guide rail and turnstile allows a Person to slip through, without completely turning Turnstile arm.

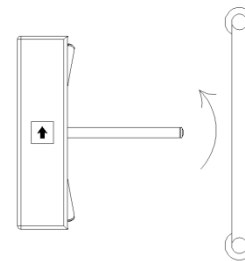

Install guide railing not more than 2" Away from end of turnstile.

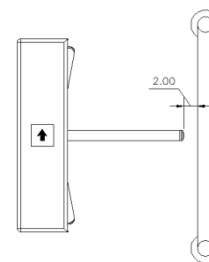

PRODUCT DIRECTION CHART

Determining product swing or turn direction can be a daunting task. Follow the tips on this chart to learn the proper identification traits of each product.



#110-L



#1100-LSS

3Arm Turnstiles: Cabinet on the approach side

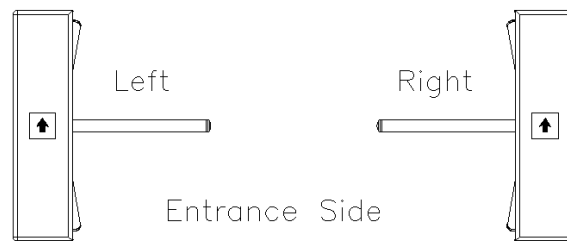

3ARM TURNSTILE: DIMENSIONS

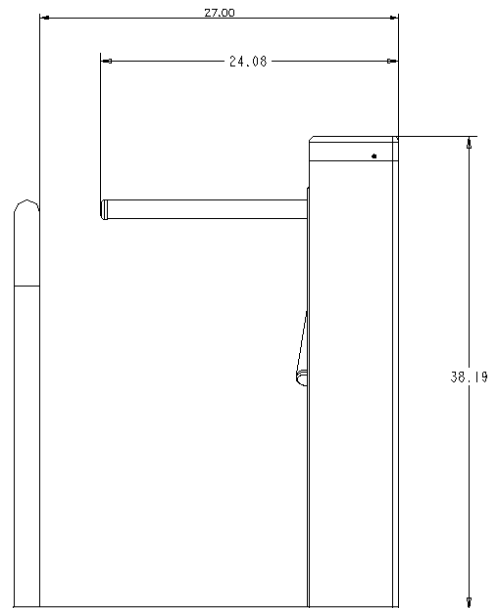
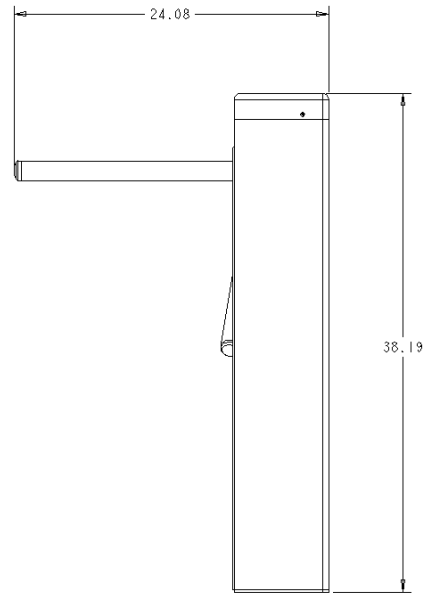
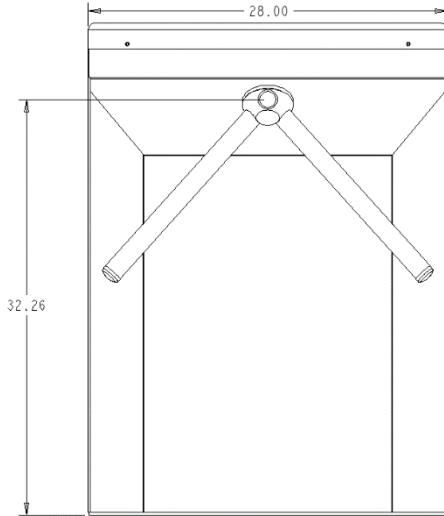

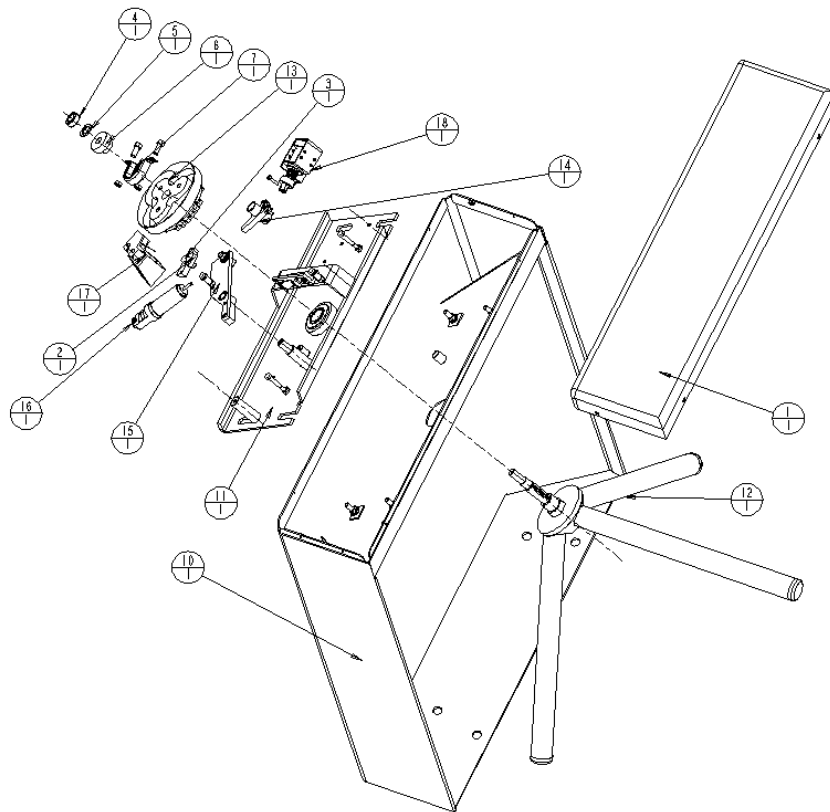
PARTS GUIDE AND LIST**PARTS LIST**

ITEM	PART NO.	DESCRIPTION	MODEL_NAME	RAW MATERIAL SIZE	VENDOR INFO	QTY
1	WH3A-101	TOP COVER	WH3ARM-GATE-TOP-COVER	16 GA(0.0625 IN) THK		1
2	WH3A-102	INDEXING PAWL	WH3ARM-GATE-INDEXING-PAWL	-		1
3	WH3A-103	STANDARD	WH3ARM-GATE-INDEXING-PAWL-BOLT	1/4-20 X 0.85 X 2 L-		1
4	WH3A-105	STANDARD	WH3ARM-GATE-MAIN-SPINDLE-NUT	5/8-18-2A UNF,0.37THK		1
5	WH3A-105	STANDARD	WH3ARM-GATE-MAIN-SPINDLE-WASHER	.625(ID)X 1(OD)X.125THK		1
6	WH3A-106	STANDARD	WH3ARM-GATE-UPPER-BEARING	BORE 1/2 IN		1
7	WH3A-107	STANDARD	WH3ARM-GATE-BEARING-HOUSING-TOP	0.0625 THK		1
8	WH3A-108	STANDARD	WH3ARM-BEARING-HOUSING-BOLT	5/16-18UNCX0.75L		2
9	WH3A-109	STANDARD	WH3ARM-BEARING-HOUSING-NUT	5/16-18 UNC		2
10	WH3A-200	CABINET WELDMENT ASSY	WH3ARM-GATE-CABINET-WELDMENT	SEE PART DRG		1
11	WH3A-300		WH3ARM-GATE-BASE-PLATE-ASSY	SEE PART DRG		1
12	WH3A-400	ARM HOUSING ASSY	WH3ARM-GATE-ARM-HOUSING-ASSY	SEE PART DRG		1
13	WH3A-500	INDEXING ASSY	WH3ARM-GATE-INDEXING-ASSY	SEE PART DRG		1
14	WH3A-600	LOCKING-PAWL-ASSY	WH3ARM-GATE-LOCKING-PAWL-ASSY	SEE PART DRG		1
15	WH3A-700	INDEXING CAM ARM ASSY	WH3ARM-GATE-INDEXING-CAM-ARM	SEE PART DRG		1
16	WH3A-800	SHOCK ABSORBER ASSY	WH3ARM-GATE-SHOCK-ABSORBER-ASSY	SEE PART DRG		1
17	WH3A-900	MICROSWITCH ASSY	WH3ARM-GATE-MICROSWITCH-ASSY	SEE PART DRG		1
18	WH3A-1000	SOLINOID MOUNTING ASSY	WH3ARM-GATE-SOLINOID-MOUNT-ASSY	SEE PART DRG		1

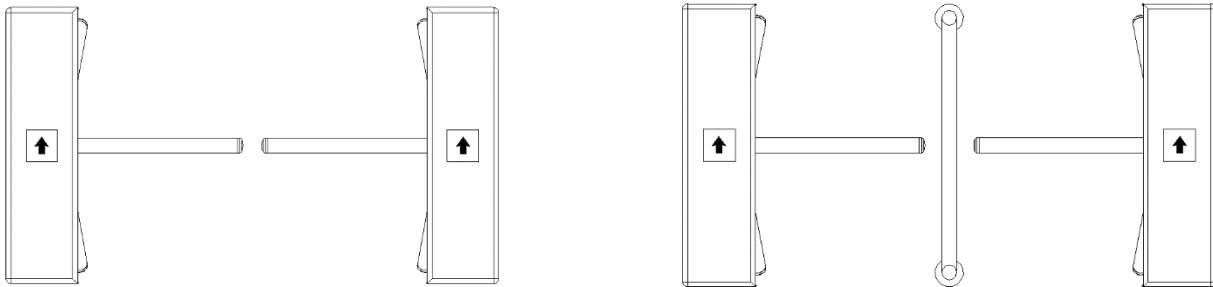
INSTALLING FACING TURNSTILES**WRONG WAY**

In plan #1 people tend to walk in the centre, turning both turnstiles thus cutting down passage capacity.

In plan #2 A single rail in between adjacent passageways will cause interference between patrons, Thus cutting down passage capacity.

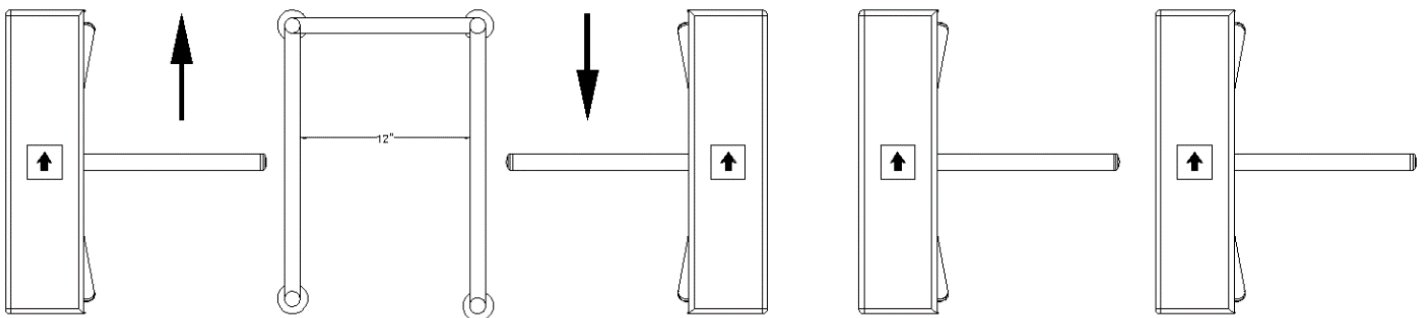
RIGHT WAY

Using a “U” railing formation will extend the field of interference and allow for steady pedestrian flow. Allowing for sample elbow room is critical between facing turnstiles. The example shows a min of 12”.

GUIDE RAIL TOO HIGH

WRONG

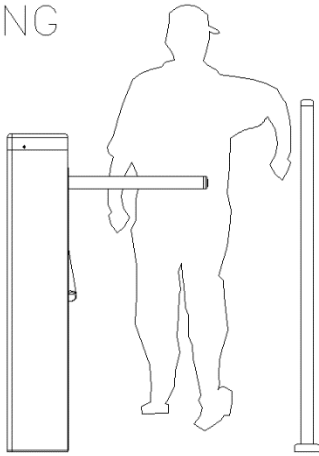

When guide rail is over 38" high
People passing by are cramped
For elbow room.

RIGHT

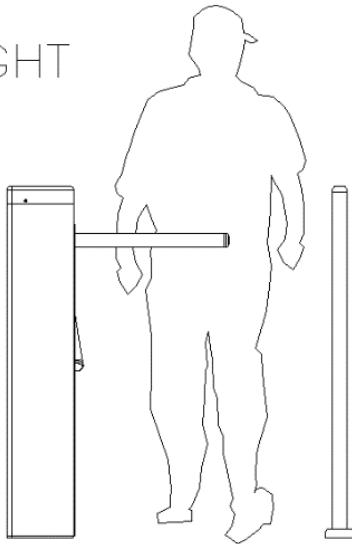

The guide rail should be 38" high.
This gives ample room and makes
For easy and comfortable passage.

WRONG

People tend to shy

Away from the wall

And are cramped going

Through the turnstile.

Install a guide rail opposite

The turnstile arm to provide

Space for elbow room.

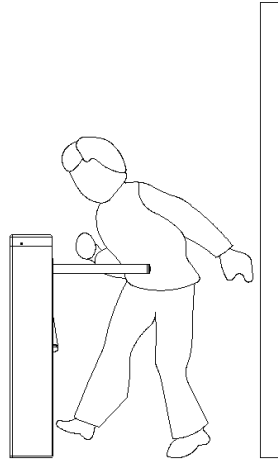
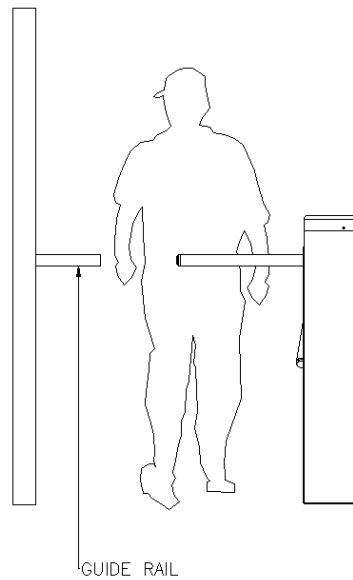
**RIGHT**

ELECTRIC TURNSTILE PAWL SET UP

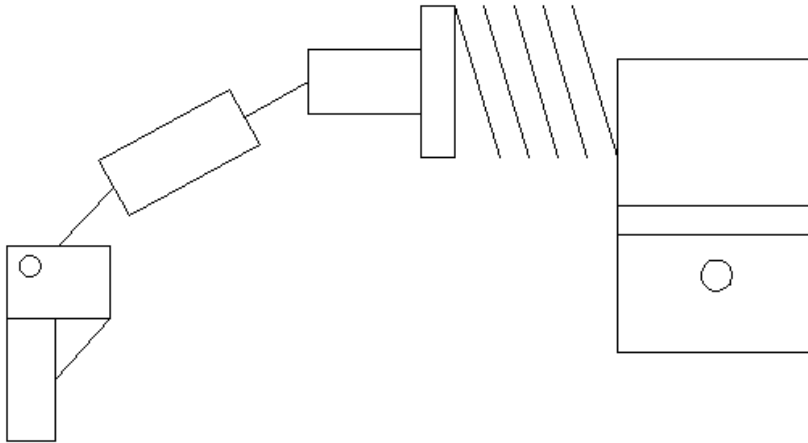

Left hand pawl layout

Make sure to use the upper mounting hole for left application. Located on mechanism plate.

Right hand layout

Make sure to use the lower mounting

Hole for right hand application.

Located on mechanism plate.

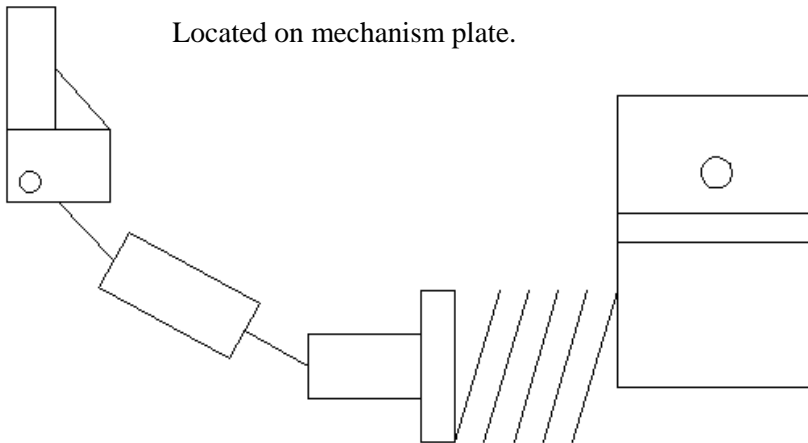

GATE WIRING DIAGRAMS

ENTRANCE GATE

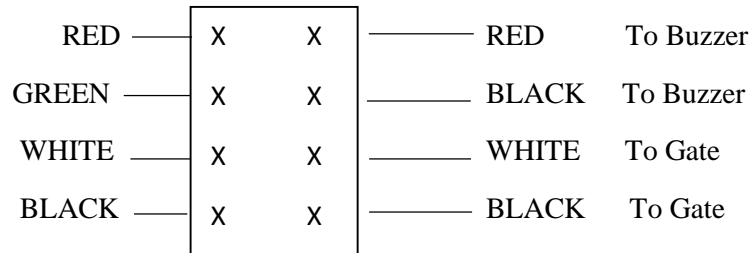

OPTIONAL



COM PORT #1

Computer Interface

EXIT GATE

From Power

Supply

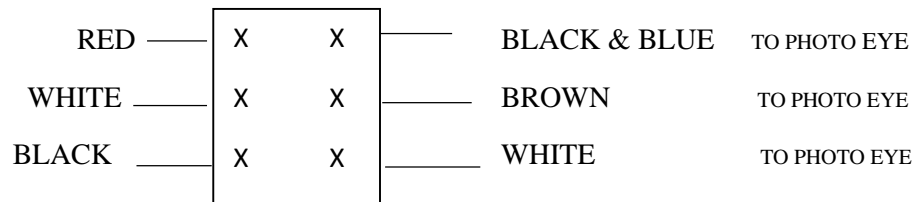

From power

supply

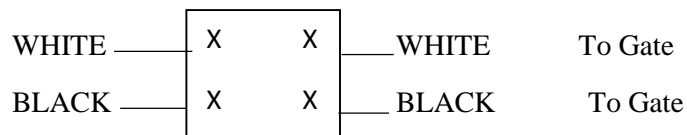

TURNSTILE

FROM POWER

SUPPLY

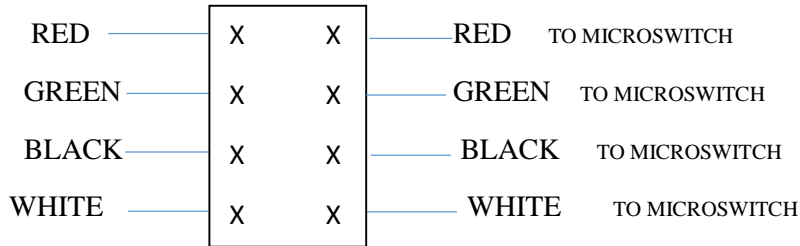

USING WEDGE ANCHORS

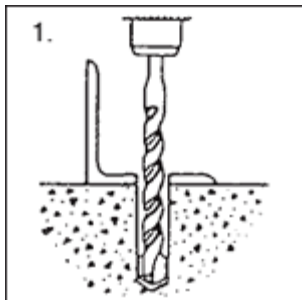

Using a bit whose diameter equals the anchor diameter, drill hole to any depth exceeding minimum embedment. Holes should be drilled using a bit conforming to ANSI B212.15-1944

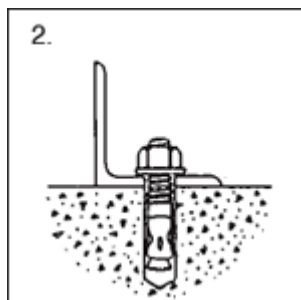

Clean hole of debris

Assemble the nut washer drive anchor through material to be fastened.

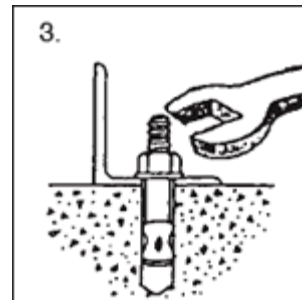

Expand anchor by tightening nut 3 to 5 turns.