

LOCKABLE GATE



SCOPE OF OPERATION

- Manual locking gates were originally designed for check out closures but they are also widely used for handicap access and barriers where limited access is required. This gate features a manual locking mechanism and break away panic feature.
- Closure gates are used to block the passage of low pedestrian traffic. They are unlocked manually by the customer or a staff member.

MATERIALS

All materials meet the ASTM standards as set forth by the materials industry.

- The gate post is constructed out of 14 gauge tube
- Mechanical breakaway mechanisms are made with all heat treated component parts
- Standard gate arm lengths for ADA compliance
- Complete with white ABS sign panel and channels
- Anchor bolts are hidden by a cover which snaps over mounting flange
- Custom length arms can be fabricated.

FINISHES

- Bright chrome finish
- Satin chrome finish
- Powder coat paint

OPERATION

- Allows for left hand or right hand operation. Direction is set during fabrication
- Gates will manual lock in 90 degree increments with Tumbler style key lock.
- Two way passage
- Panic breakaway provides exit path in case of emergency, direction is set during fabrication.

OPTIONS

- Universal and custom signage

ELEVATION DIAGRAM & LOCKING MECHANISM

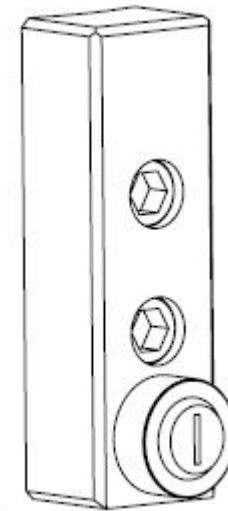
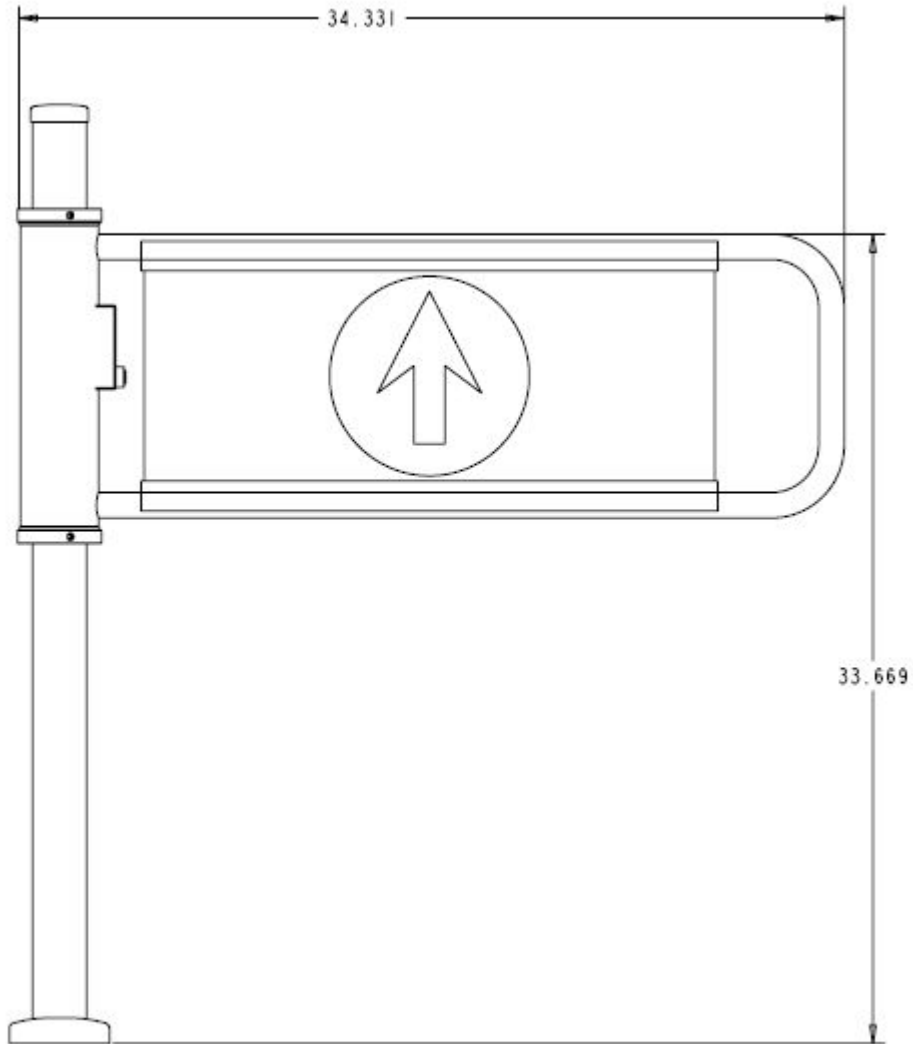

FLOOR PLAN

